

## Reflejos

\*Built-in 6 Eje

\*Modo de control Dos, adaptarse a diferentes hábito operación

\* Wiht colorido LED de luz, pueda volar en la oscuridad de la noche

## Presupuesto

\* Material: ABS

\* Tamaño Drone: 13,5 \* 13,5 \* 5,2 cm

\* Canales: 4 canales

\* Función: arriba / abajo, adelante / atrás, derecha / izquierda, vuelo hacia la izquierda / vuelo la derecha, Flips & amp; rollos, sensor de gravedad, Lanzar Mano, Cámara

\* Giroscopio: Sí

\* La frecuencia de control remoto: 2.4GHz

\* El rango de control remoto: 100 metros aprox

\* Batería de alimentación: batería de 3.7V 380mAh Li-ion

\* Batería del regulador: 4 pilas AA de 1.5V (no incluidas)

\* Tiempo de carga: Aprox 50 minutos

\* Tiempo de Trabajo: Aprox 6 minutos

\* Cámara Piexl: 0.3MP

\* Tarjeta de memoria: Micro SD de 1 GB

\* Edades apropiadas: mayores de 14 años de edad

## Contenido del paquete

1 x UFO

1 x mando a distancia

1 x Cable USB

4 x Hélices

1 x Lector de tarjetas

1 x tarjeta de 1 GB TF

1 x Destornillador

1 x Inglés manual del usuario





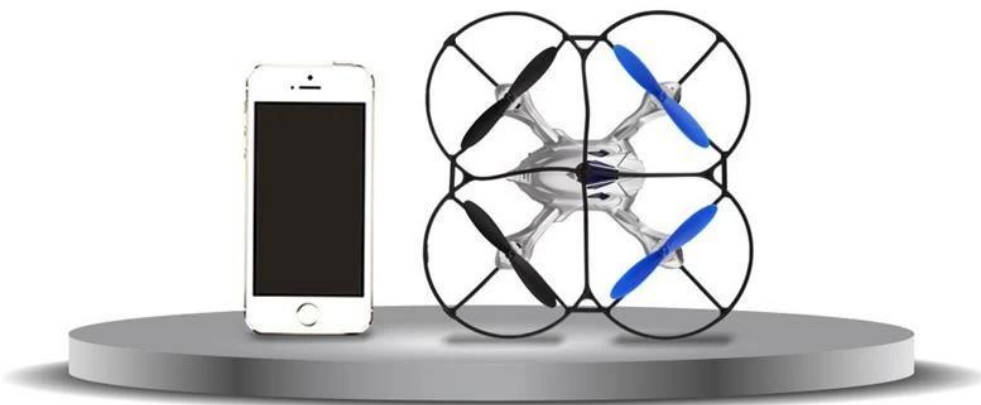
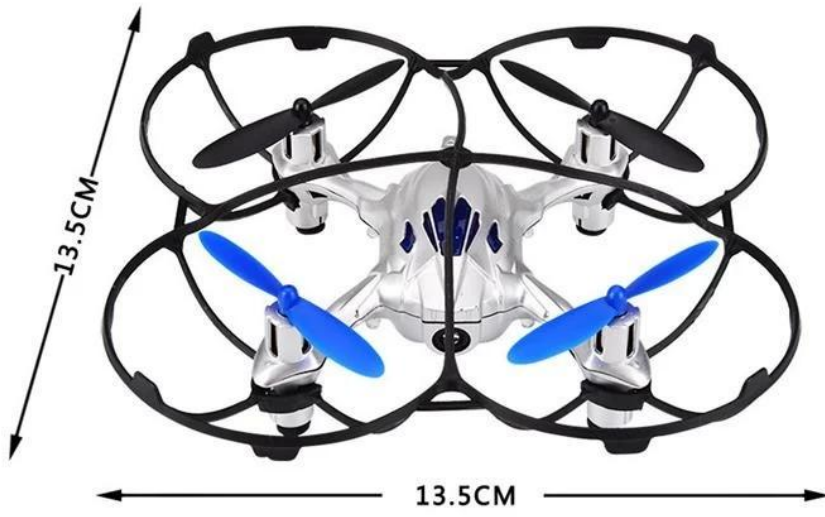



1



2



3



4

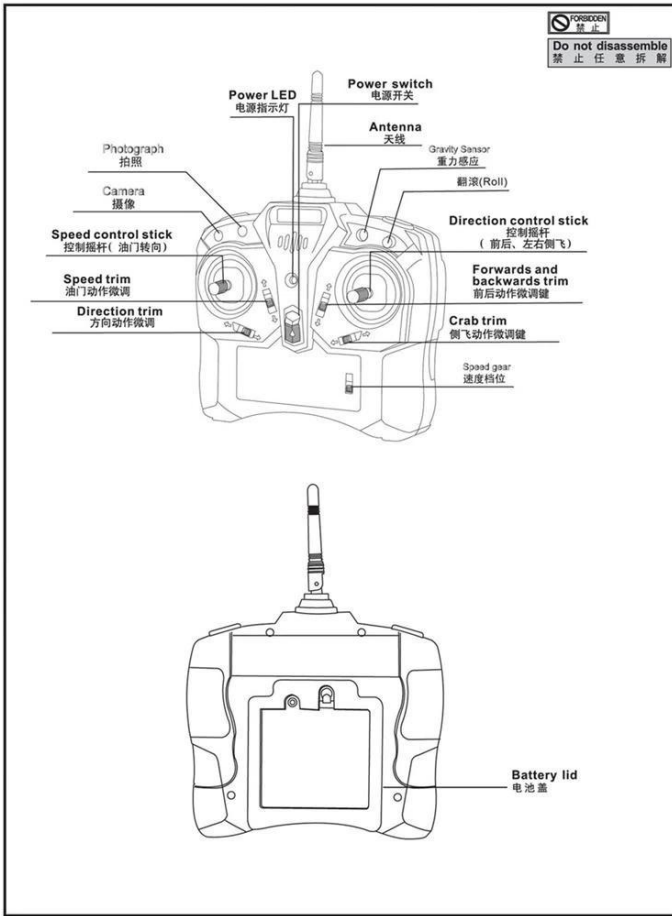

### PLEASE PRE-FLIGHT PROFICIENCY FLIGHT SIMULATION 飞行前请先熟练模拟飞行

Before you are familiar with the flight vehicle, please don't set it fly, read the instruction carefully. Get familiar with all kinds of direction control and keep repeating until you can play it as you perform your wishes.

1. Place the flight vehicle a clear open field and the tail of helicopter point to yourself.
2. Practice operating the remote control of each rocker (each operation mode of operation as shown), and repeated practice throttle high / low, left / right, front / rear and left / right operation.
3. The simulation flight practice is very important, please keep practicing until the fingers move naturally when you hear operation orders being call out.

在还没有了解飞行器各个动作的操作前，严禁实机飞行。请先阅读说明书，熟悉各种方向的操作并不断的重复，直到手指可熟练的控制各种动作以及方向。

1. 将飞行器放在空旷的地方，并将飞行器背面对准自己。
2. 练习操作遥控器的各摇杆(各动作的操作方式如下图)，并反复练习油门高/低、左/右、前/后及左/右操作方式。
3. 模拟飞行的练习相当重要，请重复练习直到不需要思考，手指能自然随着喊出的指令移动控制。

Mode	Illustration 图示	Mode	Illustration 图示
Aileron 副翼	Move left 左移 / Move right 右移	Throttle 油门	Ascend 上升 / Descent 下降
Stick 升降/前后	Fly forward 前进 / Fly backward 后退	Rudder 方向	Turn left 左旋 / Turn right 右旋

### FLIGHT ADJUSTMENT AND NOTICE FOR BEGINNERS 初学者飞行调整与注意

#### CAUTION 注意

- Check if the screws are firmly tightened
- Check if the transmitter and receivers are fully charged.

When arriving at the flying field. 请在没有人员及障碍物的空旷室内、室外飞行

#### CAUTION 注意

- Make sure that no people or obstructions in the vicinity.
  - You must first practice hovering for flying safety, this is a basic flight action. (flight vehicle means keeping the helicopter in mid air in a fixed position)
  - Please stand approximately 2m diagonally behind the helicopter.
- 确认危险地区没有人和障碍物。  
为了飞行安全，你必须先练习悬停。这是飞行动作的基础(悬停：飞行器停留在空中并保持固定位置)。  
练习时，请在飞行器后方2公尺。

### STEP 1 THROTTLE CONTROL PRACTICE 油门控制练习

#### Mode



When the flight vehicle begins to lift-off the ground, slowly reduce the throttle to bring the flight vehicle back down. Keep practicing this action until you control the throttle smoothly.

当飞行器离地后，慢慢降低油门将飞行器降下。持续练习飞行器从地面上升和下降直到你觉得油门控制很顺。